

# **pump**world

1977 VOLUME 3 / NUMBER 3

- 
- 4 Red Sea to the Mediterranean  
without the Suez Canal:  
A new wonder of the world.**
  - 7 Don't reinstall your pump problems.**
  - 12 Adventures of a field service detective.**
  - 18 Pump Refresher: Basic Hydraulics**
- 

Published by Worthington Pump Inc.,  
270 Sheffield Street,  
Mountainside, New Jersey 07092.

Editorial Board: I. J. Karassik, W. C. Krutzsch,  
R. Romani, D. N. Rush

Editor: Joseph A. Montana

© Copyright 1977, Worthington Pump Inc.,  
Mountainside, New Jersey. All rights reserved. Not  
to be copied or duplicated without the written  
permission of Worthington Pump Inc.

Offering a rare view of a large oil pipeline pump, this cutaway model of an "installed" Worthington QL type pump (with driver) gives a good idea of the size of the units in service along the Mideast's Sumed Pipeline. The man stands at ground level. An article on this new "wonder of the world" — along with pictures of the real thing — begins on page 4.



## Red Sea to Mediterranean without the Suez Canal: A new wonder of the world.

The 250,000-ton Esso Rotterdam steams up the Gulf of Suez laden with precious black liquid cargo for the energy-starved capitals of Europe.

No matter that the Suez Canal, once the gateway to the Mediterranean Sea from the oil-producing countries to the east, can't handle a ship larger than 80,000 tons. No concern that the canal might be blocked, as it has been many times in the past.

The Rotterdam stops short of the canal and moors off the terminal of Ain Sukhna, Egypt. Crewmen scurry about the decks and catwalks. Soon, they make the vital connections and the life blood of industry flows through submarine lines to terminal storage tanks. With the start of the Worthington pipeline pumps, a black river of oil begins racing across rolling desert land, across the cultivated fields and date palm orchards of the Nile River

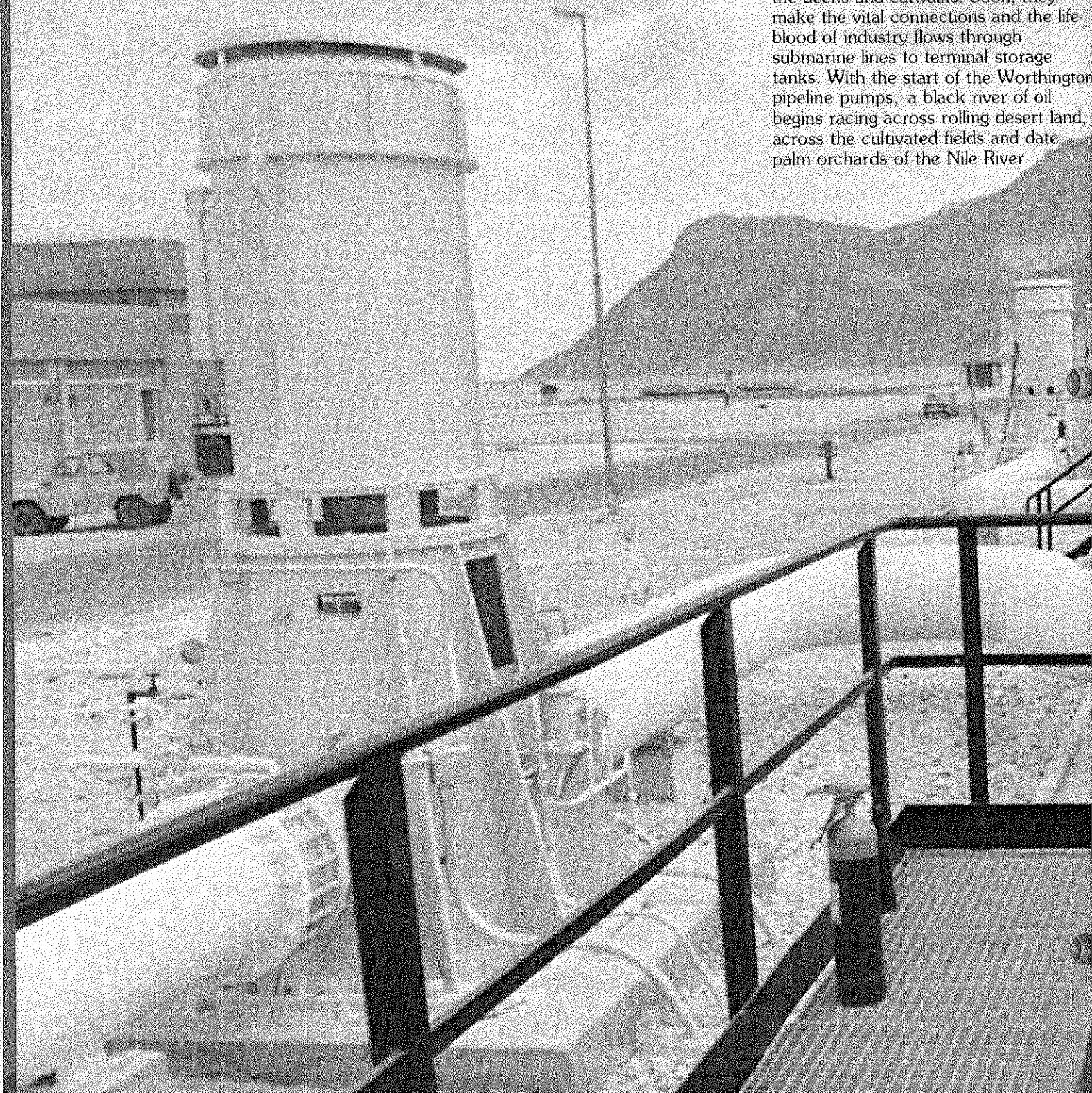



agricultural area, under the Nile River south of Cairo, again across the desert, past the ancient Dashur pyramids, and finally to the coast.

The oil is stored in storage tanks at Sidi Kerir on the Mediterranean, near Alexandria. It has traveled nearly 200 miles from the Esso Rotterdam. Soon afterward, the 150,000-ton Finnish tanker Esthel loads the crude and gets underway for European ports.

The Sumed pipeline project is nearing completion and is partially operational. To date, more than four million tons of crude oil have been delivered to the Ain Sukhna terminal.

The second of the twin pipelines to provide a vital link between the Red Sea

and the Mediterranean will be completed and scheduled for operation in the near future. The twin pipelines are designed to pump some 600 million barrels of crude oil per year. Ultimate capacity will be 900 million barrels annually with the installation of a booster station.

The Arab Petroleum Pipelines Company is building the \$500-million pipeline system as an alternative method of getting oil to Western Europe, where the black liquid is used to fill 49 per cent of the energy needs. The system will supplement traffic through the Suez Canal and provide a faster method for getting the sorely needed oil to Europe than is now possible with huge tankers

carrying it around the Cape of Good Hope.

Sumed will cut by half the time it takes to transport oil to Southern Europe via the Cape of Good Hope route and by one third the time to Northern Europe. Several oil companies have contracted to send oil through the lines.

Contractor and technical advisor for the project was Bechtel—but the project was engineered and constructed by a joint venture of Italian contractors under a lump sum turnkey contract. It was truly an international operation with Italian, German, English, French, Dutch, Belgian, Egyptian, Spanish, Japanese,



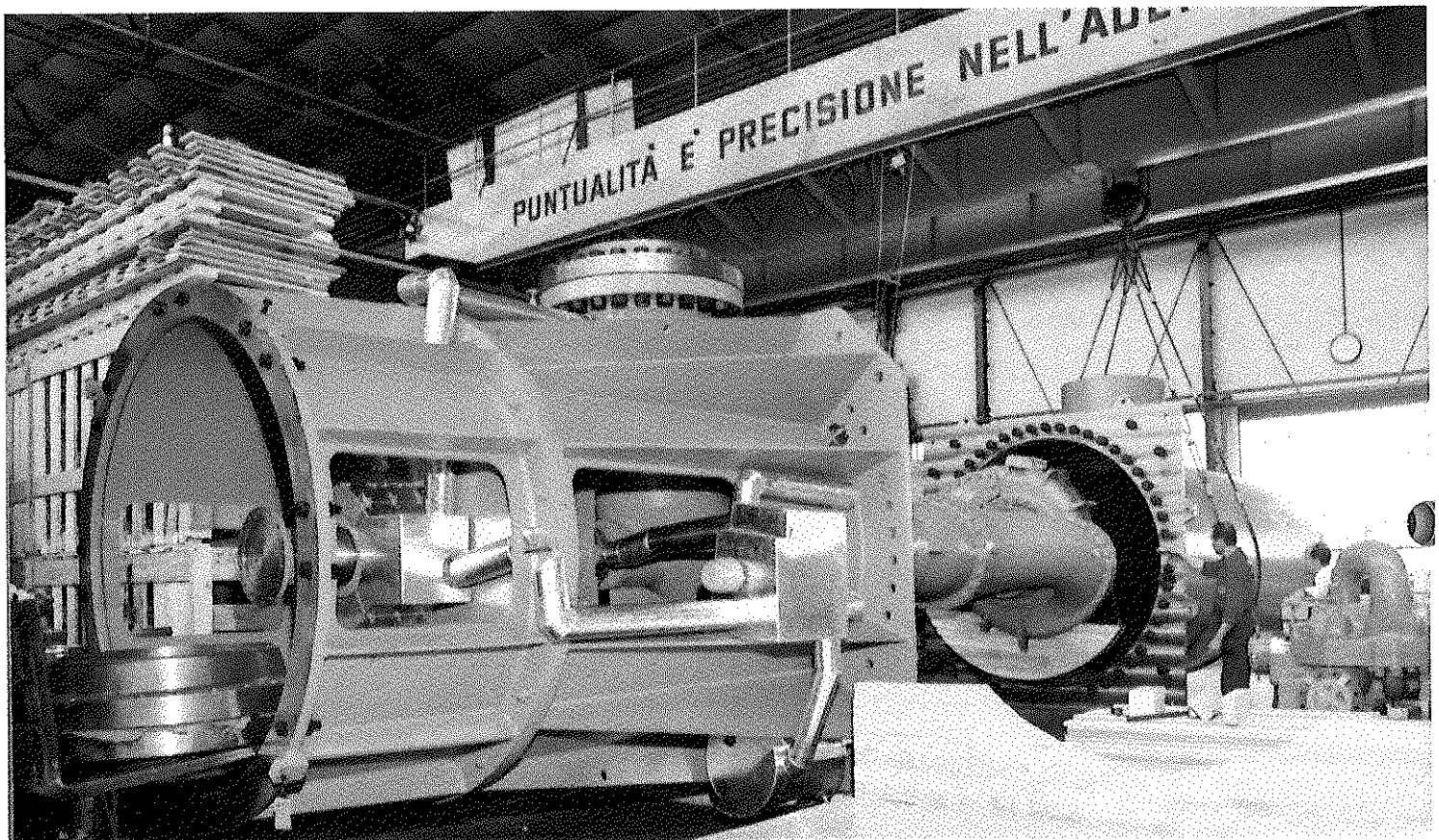

Pipeline booster pumps, ready for shipment from Worthington S.p.A., Desio, Italy.

Swiss and United States suppliers and contractors working together to help build the pipeline system.

The labor force reached 3,000 at its peak, and many an engineer or worker found himself working in the shadows of the ancient pyramids. That was not the only contrast with the past. The entire right-of-way, for example, had to be searched by demining teams for land mines, shells, and bombs—a dramatic and dangerous reminder of various military desert operations dating to World War II.

The Egyptians regard the impressive Sumed project as one of the wonders of the world, along with the pyramids and the Aswan Dam. And with good cause.

The unloading terminal in the Gulf of Suez, just south of the city of Suez,

consists of three single-point mooring buoys located two to three miles offshore. Two can handle 250,000-ton supertankers, the other a 120,000-ton oiler. Two 48-inch diameter and one 42-inch diameter submarine unloading pipelines connect the buoys to the onshore facilities.

On shore at Ain Sukhna, there are 12 steel crude oil storage tanks, each with a capacity of 650,000 barrels. The main pumping station is located within this terminal and is equipped with ten pumps, each driven by an 11,000 horsepower electric motor.

The control room building at this terminal contains the supervisory controls for the complete, computerized pipeline system.

At Sidi Kerir, there are 12 steel crude oil

storage tanks, a loading pump station, and a treatment plant for tanker ballast water.

The marine loading terminal at Sidi Kerir consists of five single point mooring buoys located three to four miles offshore. Two are sized for 250,000-ton tankers and three for 120,000-ton ships.

Two 48-inch diameter and three 42-inch diameter submarine loading pipelines connect the onshore terminal with the buoys. Two 32-inch diameter and one 26-inch diameter submarine deballasting pipelines connect the onshore ballast water treatment facilities to the buoys.

To furnish power to the system, 84 miles of high voltage transmission lines were constructed along with the necessary high voltage substation at both terminals.



# Don't reinstall your pump problems.

By E.J. Serven

Did you ever get the feeling that you aren't getting the same service out of your pumps as you did when they were new? Well, there are many things that can happen to pumps to cause maintenance to increase. Most of these can be corrected and original serviceability restored. But, first it's necessary to find out what's causing the problem. Here's how you can take measurements on your pumps during rebuilding to make sure you've located the trouble before reinstalling the pumps.

The most frequent source of maintenance problems is the stuffing box, whether it be packed or equipped with a mechanical shaft seal. Therefore, we will limit ourselves to considering this area in our discussion. Since adequate information exists on installing, adjusting, and maintaining packing, and since mechanical seals are supplied with similar instructions, we will assume that such instructions are properly applied and will focus instead on checking the condition of the pump itself.

Before we go further, let's make a checklist of the basic items to be reviewed in solving a stuffing box maintenance problem:

### Application.

Is the proper packing or mechanical seal being used? Does the shaft or shaft sleeve material have the proper corrosion resistance, hardness and surface finish? Is the mechanical seal equipped with the correct conditioning connections (bypass, flushing, etc.)? Should the packing be arranged for use of a seal cage (lantern ring), and if so, will the liquid be bypassed from the

*Ed Serven is manager of training and development for Worthington Pump Inc.*

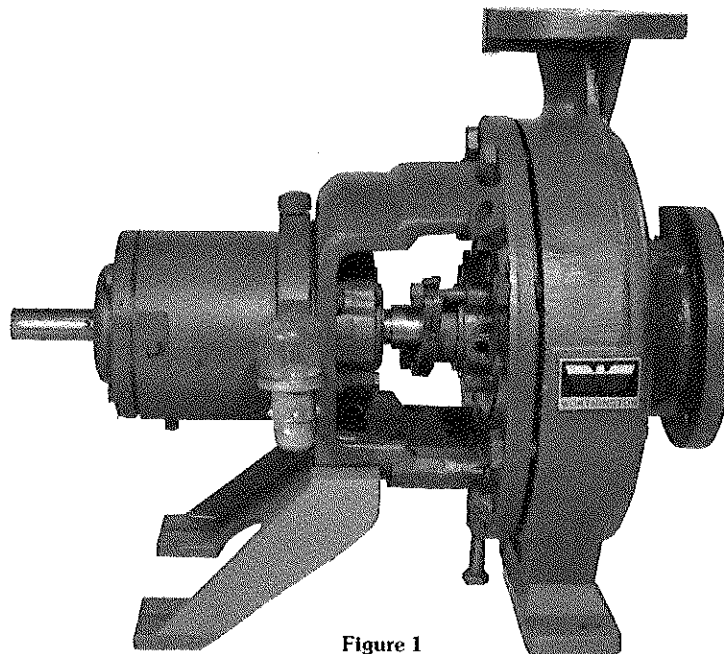

Figure 1

pump itself or must an independent source of liquid be supplied?

### Installation.

Are instructions for installation of packing or mechanical seal being followed? Have all worn parts been replaced? (Mechanical seal parts of Teflon® should be considered useable for one installation only. Removing and reinstalling such parts may allow leakage since Teflon may take a 'set' during the first installation.) Is the pump coupling aligned properly? (This is important on any pump to prevent bearing failure, but also can cause mechanical seal vibration and failure.) Have casing distorting pipe strains been avoided? Has dirt been removed from system?

### Operation.

Is the pump cavitating or running dry? Are all conditioning liquids flowing properly? Are excessive shaft bending loads being built up by operating the pump with a closed or drastically restricted discharge valve setting? Are steps taken to prevent crystallization or solidification of liquid, particularly during periods when the pump isn't running?

Let's assume that you are sure the application, installation, and operation are correct, but you still have a problem of excessive leakage. Your next step is

to disassemble the pump to check further. Let's take a look at the checks you should make.

Figure 1 shows a pump design which is typical of those on which you may want to take measurements to determine the unit's condition, and we will use it to illustrate the measurements.

In order to understand why each measurement is made, it is important to remember that, in order to have proper

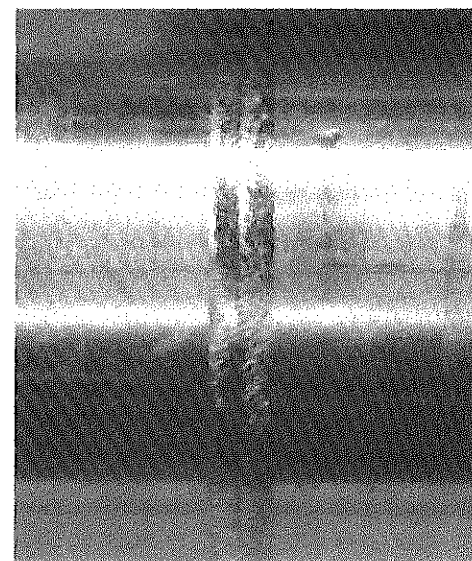

Figure 2—Check for evidence of fretting.

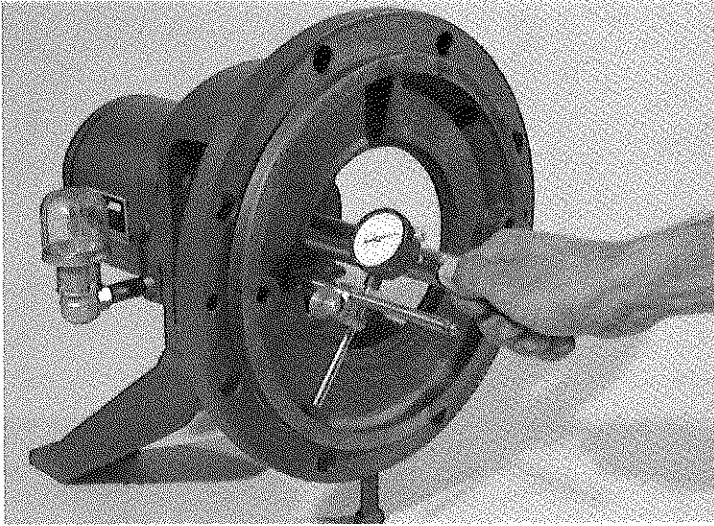

Figure 3—Check for loose bearing fit.

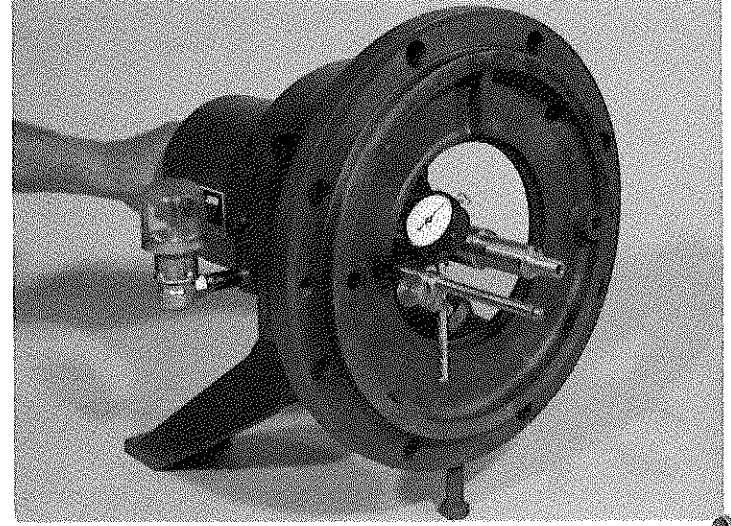

Figure 4—Check for bent shaft.

packing or mechanical seal performance, the pump shaft must run 'true' in the stuffing box. 'True' means that the shaft must be co-axial with the box bore, and perpendicular to any mechanical seal faces held stationary on or in the box. If the shaft isn't 'true', it will deform the packing, opening an enlarged leakage path.

With mechanical seals, the result will be axial oscillation of the rotating, flexible

rotor member as it attempts to maintain face contact with the stationary member. Sometimes the misalignment will be so severe that the rotating face, although flexibly mounted, cannot maintain this face contact. 'Chattering' then results which not only allows leakage but may damage or break the seal faces.

Another result of this axial oscillation is 'fretting' or chafing of the shaft or sleeve

under the static sealing ring (shaft seal packing) in the rotor of the mechanical seal. Figure 2 shows the result of this fretting and the disassembled pump parts should be examined for such evidence.

**Step 1. Check for loose bearing fit.**

First, a measurement should be taken to determine the relationship of the shaft to the bearing housing at the area where the adapter supports the casing (looseness can occur between shaft and

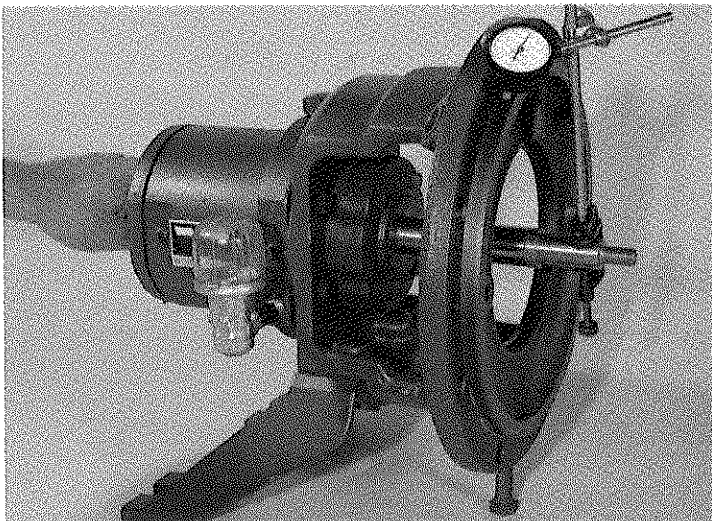

Figure 7—Concentricity of shaft to stuffing box mounting fit on bearing frame.

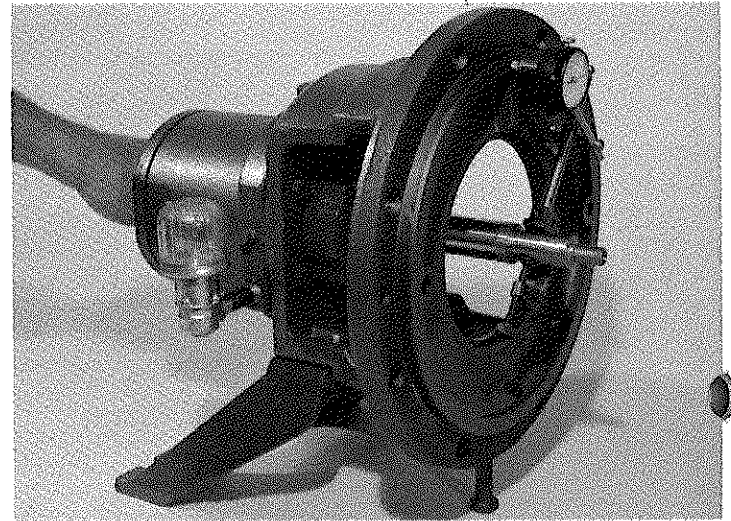

Figure 8—Angular alignment (fit perpendicular to shaft) or shaft to stuffing box fit.



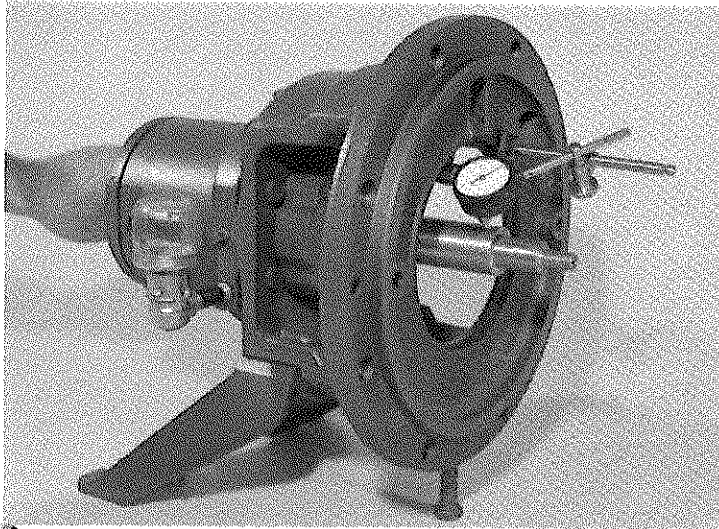

Figure 5—Check for sleeve concentricity.

bearing or between bearing and bearing housing).

Clamp dial indicator to adapter at casing support point and indicate shaft as set up in Figure 3. Grasp impeller end of shaft and move toward dial and then away from dial. Note total movement of shaft. Do not exert more than a few pounds of load since the intent is to measure the total bearing looseness (internal and external) rather than

bending of the shaft under load. A total reading of more than 0.005" should be considered excessive. (Part of this looseness is due to internal bearing clearance. If the pump is fitted with C-3 bearings, which have about twice the internal clearance of 'standard' bearings to allow satisfactory operation at elevated temperatures, this value would be higher at room temperature.)

Correct any looseness problem before

proceeding. A common cause of bearing looseness is an enlarged bore in the bearing frame. This enlargement is often the result of a previous bearing failure which caused seizing of the bearing, after which the driver continued to rotate the bearing in its housing. This 'hones' out the bearing bore in the housing. Many of these housings are relatively inexpensive, and it is generally recommended that they be replaced

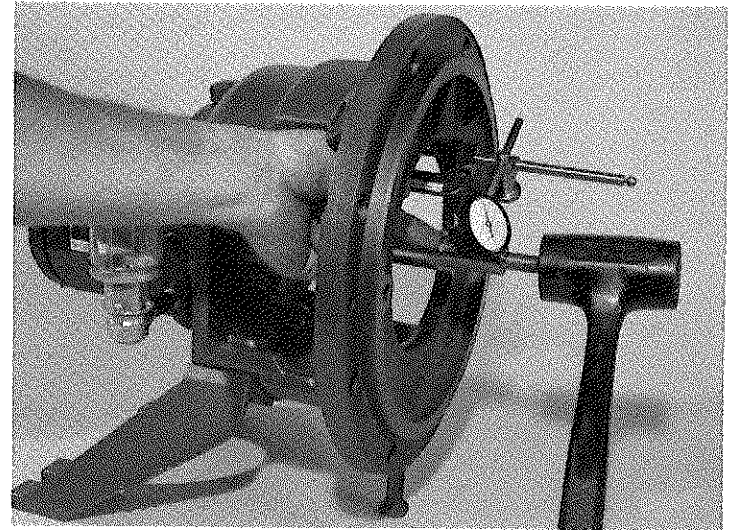

Figure 6—Check for shaft end play.

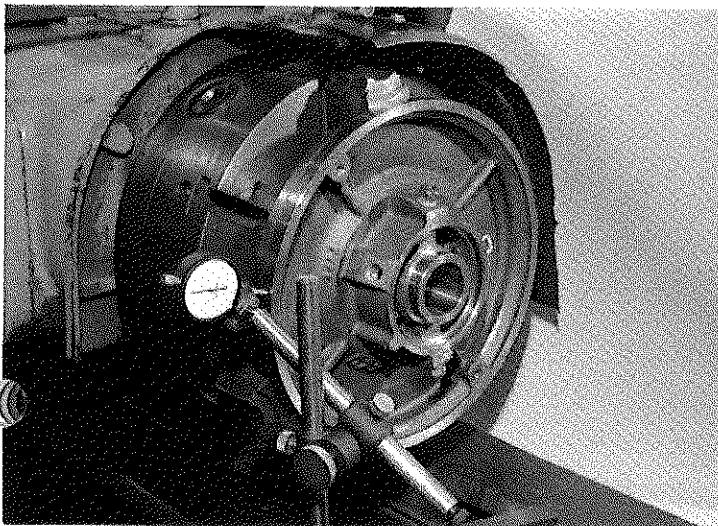

Figure 9—Check whether stuffing box cover is running true radially.

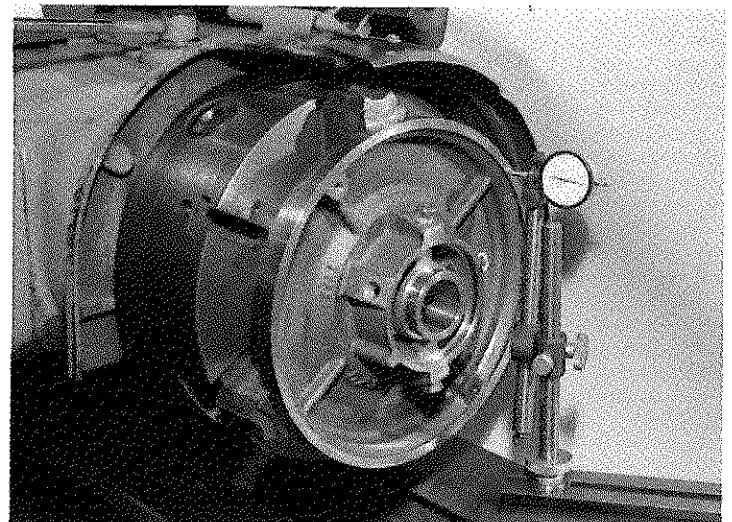

Figure 10—Check whether stuffing box cover is running true axially.

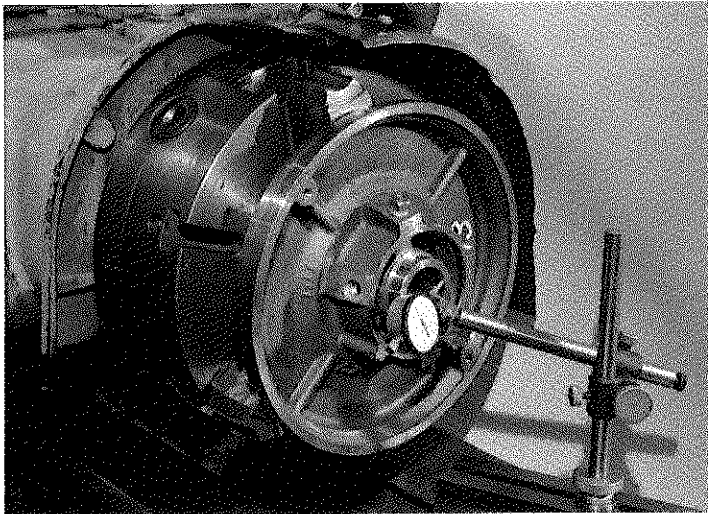

Figure 11—Check for concentricity of stuffing box bore.

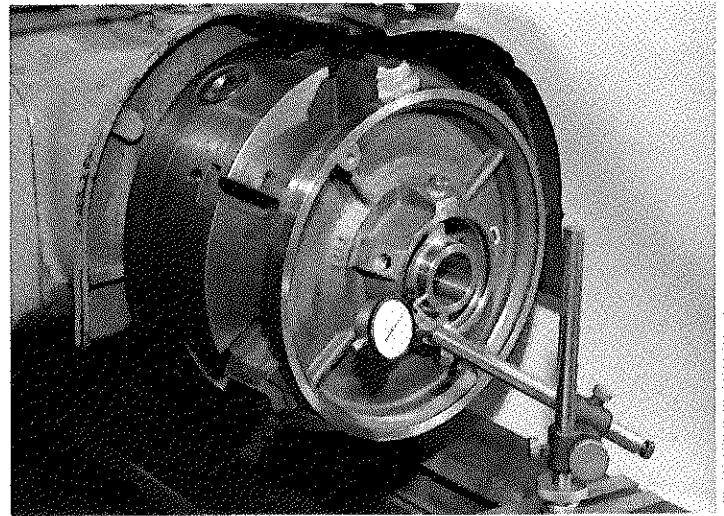

Figure 12—Check concentricity of stuffing box pilot with mounting

rather than rebuilt.

### Step 2. Check for bent shaft.

Keep dial indicator placed as before but now set indicator at zero and rotate shaft by turning from *coupling end* by hand (Figure 4). As the shaft is rotated, the total indicator movement should not exceed 0.002".

### Step 3. Check for sleeve concentricity.

If the shaft is not bent, and bearings not loose, the shaft sleeve can be checked on the shaft by installing it as it would normally be installed, leaving the impeller off (Figure 5). With the indicator clamped to the adapter, the sleeve is indicated by rotating the shaft from the *coupling end*, by hand. A total indicator reading of more than 0.002" is excessive.

### Step 4. Check for shaft end play.

Excessive internal thrust bearing looseness, or looseness of the thrust bearing on the shaft or in its housing, may allow the shaft to move axially under certain conditions. To determine if this problem exists, clamp the dial indicator to the pump adapter and position it to indicate the end of the shaft or a convenient shaft shoulder. To prevent the indicator from bouncing, lift indicator pickup off shaft, while tapping

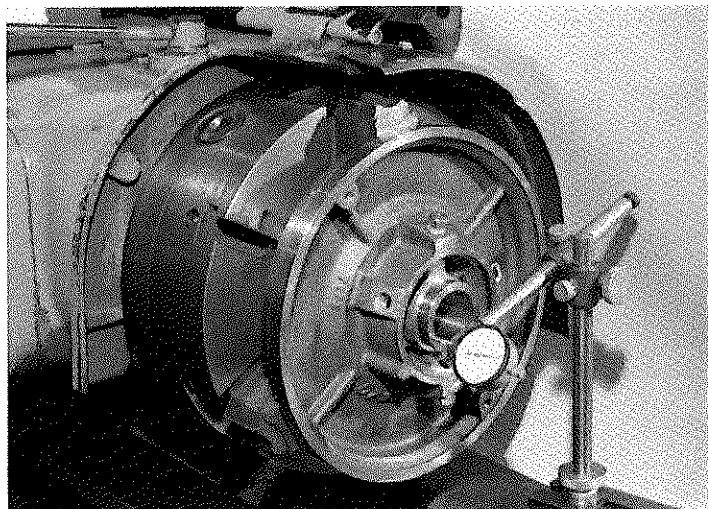

Figure 13—Check for angular alignment of stuffing box face to mounting ring face.

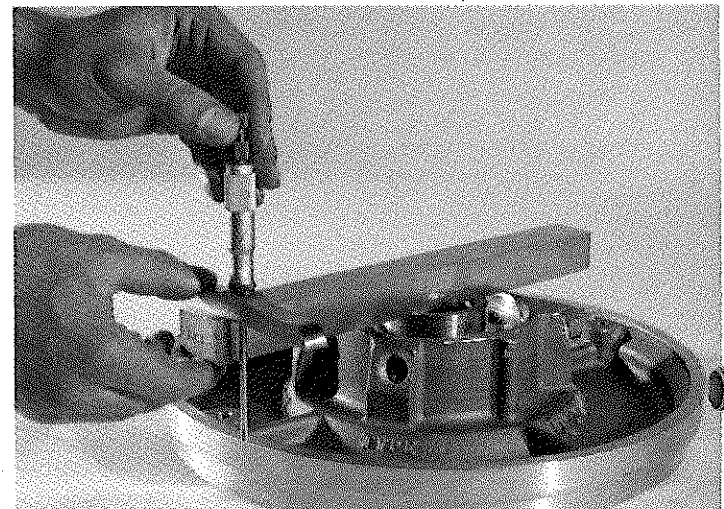

Figure 14—Check for angular misalignment of stuffing box face to mounting ring face by use of straight edge and depth micrometer.



gently with soft hammer or wood. After tapping, gently return indicator pickup to shaft shoulder, and note reading. Lift indicator pickup, tap at the opposite end of the shaft and gently return indicator, noting any difference in readings (Figure 6).

When mechanical seals are used, axial movement of the shaft with respect to the shaft seal packing may cause scuffing of the parts. A total movement of over 0.005" is excessive.

Having determined that the shaft is not bent nor the bearings loose (or if so, having corrected the situation), it is now necessary to determine the relationship between the shaft and the stuffing box bore, face and pilot. When you work on pumps of other designs, it is only necessary to examine the specific pump and note the relationship between the stuffing box and shaft, through whatever intermediate pieces connect the two, in order to deduce how to apply an analogous series of measurements.

**Step 5. Check concentricity and angular alignment of shaft to stuffing box mounting fit on adapter.**

Clamp the dial indicator to the shaft and indicate the surface of the mounting fit which is parallel to the shaft as shown in Figure 7, turning the coupling end of the shaft. A total indicator reading of more than 0.004" is excessive.

Note that reading illustrated in Figure 7 only determines if the mounting fit is concentric with the shaft, but does not show whether the fit is perpendicular to the shaft. This is done as follows: With the indicator clamped to the shaft, indicate the radial face of the mounting fit (Figure 8). A total indicator reading of more than 0.0005" per inch of diameter of the mounting ring is excessive.

**Step 6. Check concentricity and angular alignment of mounting ring fit on stuffing box member to stuffing box.**

Set up the stuffing box cover in a lathe and adjust it so that the mounting ring fit runs true radially (Figure 9), and axially (Figure 10).

Concentricity can then be checked by indicating stuffing box bore after having centered the mounting ring (Figure 11). An off-center reading of over 0.003" is excessive.

On many pumps equipped with mechanical seals, a pilot fit is machined by turning the outside of the end of the stuffing box. Figure 12 shows this turn being checked for concentricity with the mounting fit. Again, an off-center reading of more than 0.003" is excessive. Angular misalignment of the stuffing box face to the mounting ring face can be checked while the piece is in the lathe (Figure 13). If no lathe is available, a straight edge can be laid along the stuffing box face and the distance to the mounting ring measured with a depth micrometer (Figure 14). A total reading difference from one side to a point on the opposite side of either the stuffing box face or mounting ring (whichever is measured) is excessive if it exceeds 0.0003" per inch of diameter of the measured circle.

With the information gained from the readings taken in the previous steps, any necessity for rebuilding will be immediately evident.

But before installing the mechanical seal

parts, it is well to check the stationary member (seat, gland insert, etc.) and gland (clamp). Designs vary, but by observation of a particular design you can determine what surfaces, related to one another, hold the stationary face perpendicular to the stuffing box bore. These related surfaces should be checked for parallelism. Figure 15 shows a ceramic stationary member being checked for parallelism between the sealing face and the mounting face by taking a series of thickness measurements around the piece. A total reading from any point to a point opposite of more than 0.0003" per inch of diameter of the measured circle is excessive.

Finally, during reassembly, be sure there are no nicks, burrs, dirt or other irregularities on any mating surfaces which would cause uneven mating.

You have seen how measurements can be made on related pump parts to eliminate the possibility of reinstalling parts which will make trouble-free performance impossible. You can assure yourself of 'factory fresh' performance from well-maintained pumps. Insure this performance by making these procedures a part of your pump maintenance program.



**Figure 15—Carbon stationary face being checked for parallelism between sealing ring face and mounting face.**

# Adventures of a field service detective.

By R. D. Bright

Sometimes field service is relatively simple: Perceive a problem. Apply skill and logic to correct it. It's a fairly straightforward procedure, even though it may involve a rather hectic 16-hour workday until the "fix" is made.

Other times, perceiving a problem is only the beginning of a mystery. Like the bumblebee—proclaimed by science to be incapable of flight, but buzzing along all the same—a pump doesn't always stay within the limitations prescribed by

engineers. Tie that pump into the infinite variables of a fluid system, and the possibilities for complications can be endless. Anything can happen!

On call around the clock and ready to provide fluid handling assistance anywhere in the world, the Worthington Pump field service organization has cracked some of the toughest cases. Here are some of their most notable ones—and how they solved them.



*Bob Bright is manager, field service and systems, for the Engineered Pump Division, Worthington Pump Corporation (USA).*



## The case of too many cooks.

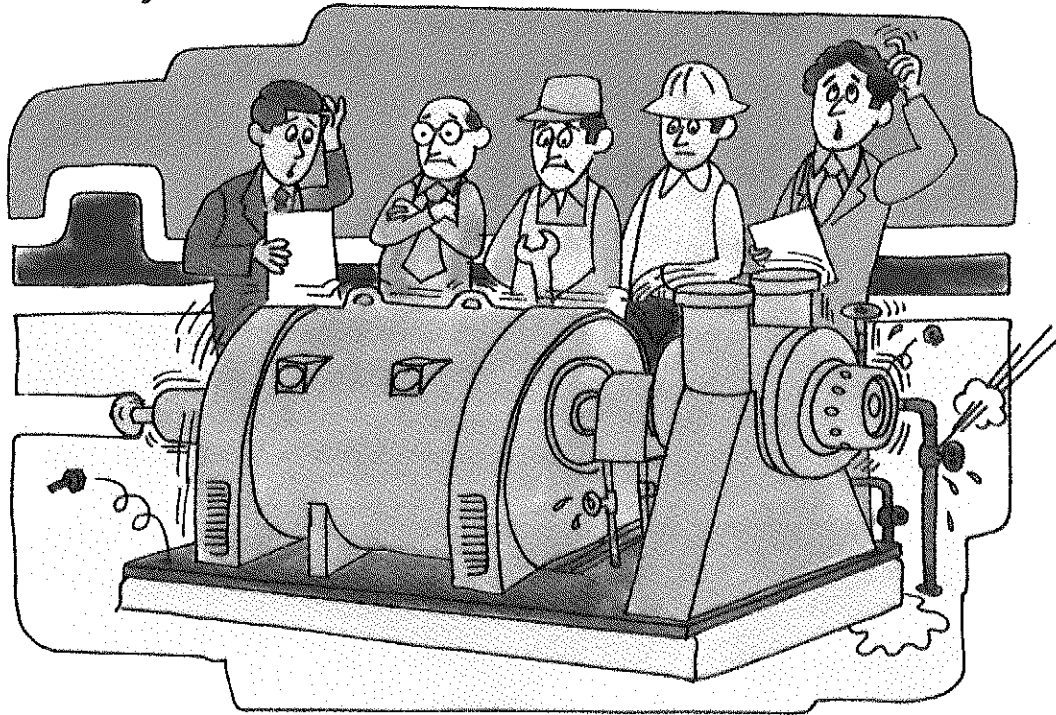

Not too long ago we were reminded why one of the many concerns in engineering a pump relates to vibration and resonance. Problems occur when the natural frequency of a pump is close to its running speed. If, for example, the resonant frequency of a given pump is 800 cycles per minute and the speed of the pump is 800 revolutions per minute, any dynamic unbalance will be amplified through the structure. It must be understood that, no matter how carefully a piece of rotating equipment is balanced, there is likely to be some dynamic unbalance inherent in it.

After careful calculation by engineering, and a careful balancing job by manufacturing, a pump goes into the field to be put on a baseplate and piped up to a system. But as soon as this is done, the pump becomes a structural part of the total system, of entirely different mass, and a totally different resonant condition can occur.

How is such a problem solved in the field? The basic objective is to change the resonant

frequency of the system, which can be done by adding mass, subtracting mass, stiffening up the system or the reverse. In other words, correcting a resonance problem is often as much an art as a science.

Recently we faced a particularly perplexing problem of vibration produced by a pump and its motor. After trying several simpler solutions, we finally decided to remove the fabricated steel base altogether and grout the motor directly onto a concrete pad: The idea was to add mass and stiffen the system. This was done, the motor was started up—but the system continued to hum like a tuning fork worse than ever.

Consternation gave way to resignation, and we settled down to investigate the continuing problem. We found a classic case of too many cooks spoiling the broth.

The designer of the concrete block wanted it good and strong, so he specified plenty of

reinforcing bar. Steel tie rods were used for this “rebar.” Next, the installation crew came along and, since those steel tie rods were so handy, they took advantage of them to fasten down their anchor bolts. As a result, we had carefully removed one vibrating metal component—and tied into another which was even worse.

The solution was simply to drill into solid concrete to set the anchor bolts, so there was no metal-to-metal connection between the rotating machinery and the steel tie rods. In no time the pump was running acceptably—further proof that strange things do happen!

### **The case of the abominable dust.**

It all began somewhere in the Southwest when several vertical turbine pumps were installed to operate intermittently in a remote wet pit. They were to be used for storm drainage. In case of a flash flood, storm water would drain into the pit, and at a certain water level the pumps would automatically go into operation to send the water to a river some miles away. Like most vertical turbine pumps on conventional water service, these pumps had bearings lubricated by the water they were pumping.

Unrealized by all, the water flooding the pits carried minute particles of iron ore and adobe dust. After the rush of the flood subsided, the ore and dust would settle out in the suction basin. Of course filters and sand caps were provided to keep out impurities, but the super-fine adobe dust and iron ore were sneaking through, into the pumps and their bearings. The problem wasn't acute when the water was high and the contaminants fairly well diluted, but once the pit was nearly drained the pumps were slurping up a fairly thick slurry.

Summer came, there was no more rainwater to flush the pumps, temperatures shot up to the 90's and above, and the adobe slurry—that same compound used by the Indians and early settlers to make their mud houses—spent the summer baking inside the pumps. When the fall rains

began and the pumps were called on to operate, operators found their supposedly rotating parts firmly cemented in place with a thick grout of iron-ore-reinforced adobe!

As so often happens, once the problem was completely understood the solution became apparent. The pit was cleaned out, and a new arrangement made to provide a settling basin well separated from the pump suction. For further insurance, the pumps were provided with an independent, automatic bearing lube system. The only remaining problem was the possibility of residual adobe mud settling out in the pumps' wearing rings after they were shut down. The solution here involved a simple maintenance procedure. A week or so after the pumps are operated, they are routinely flushed with clean city water.

It was a clear-cut solution, but not a simple one. To clean the suction pit of the accumulated muck composed of iron ore and adobe dust, bulldozers had to be lowered into it with a crane!

### **The case of the terrible thrust.**

We'll never forget the 4-stage balanced opposed pump on descaling service that was doing well—except for the thrust bearings on the inboard side, which had to be replaced every two weeks or so.

Obviously, this would never do. After on the spot research and testing, we discovered that when the pump operated back on its curve, the inboard bearing would load up very heavily, to the point where the bearing housing was deflecting nearly 1/8 of an inch. This was obviously an impossible situation, so we decided to relieve it with an impossible solution: We removed the first and third stage wearing rings, actually boosting the outboard thrust of the rotor—which served to relieve the inboard bearing.

It was an experiment, and perhaps it shouldn't have been effective in theory, but it worked! These pumps are now running two years or more between bearing changes.



## The case of the pampered bearings.

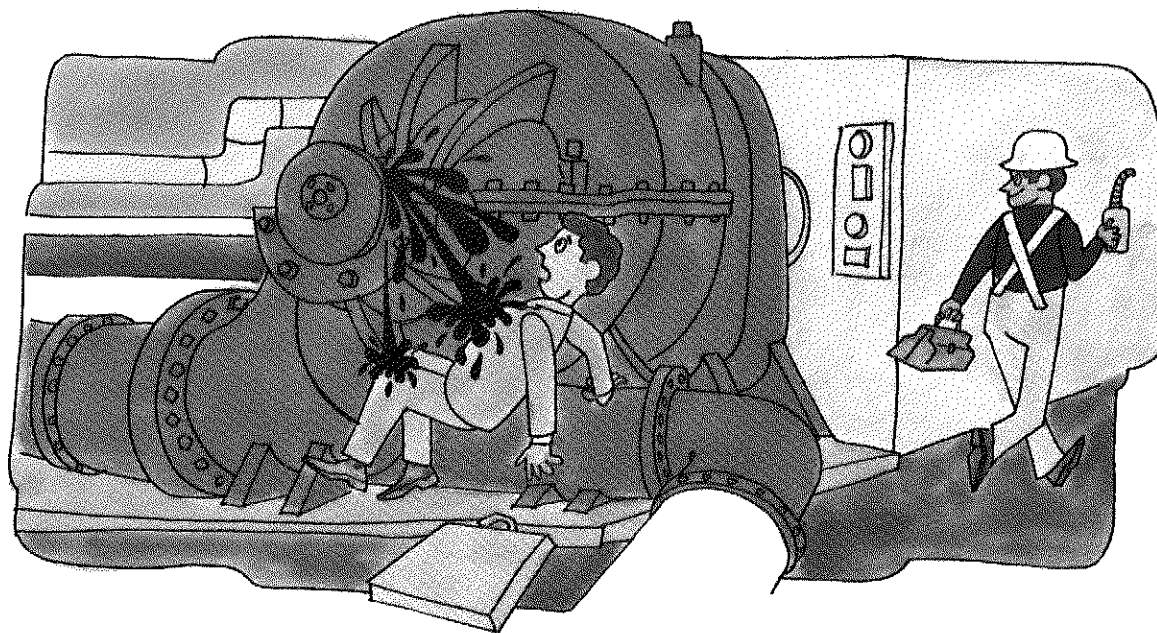

It was a lucky break that led to the quick solution of a problem in a waste treatment station some time ago. It involved an interesting facet of the human element—a man who was simply trying too hard to do a good job.

The station was a municipal showplace, with immaculate tile walls and floors. The superintendent was very proud of his “spit and polish” station.

Suddenly the pumps developed a highly disturbing problem. Once a day—always around noon—the bearings seemed to suffer from indigestion, spitting grease out all over the clean walls and floor.

The pumps were naturally blamed for this problem, the theory being that the elastic seals holding in the grease were inadequate. This was the first complaint we’d ever had of this type, but stranger things have happened, so we started our investigation.

The seals seemed to be in good condition; nevertheless, we decided on a design change to

make the seal area even *more* grease-tight. While formulating a precise course of action, we stationed a serviceman near the pumps to observe just how they were operating at the moment the grease came spilling out. While sitting and watching the pumps, our lookout spotted a man wandering through the station on his way to lunch. He was one of the old-time perambulatory mechanics holding, of all things, a greasegun. He was supposed to be outside working on some veteran reciprocating machinery—not in the pump house.

While making his way past the pumps, the mechanic suddenly bent down and shot the bearing housings full of grease. The serviceman began to explain to the mechanic that a modern pump doesn’t need all that much grease (certainly not once a day) when suddenly the obvious happened. Once again one of the pumps suffered indigestion from its unscheduled ration of lubricant. Covered with grease, but wiser, the serviceman solved the case. It wasn’t a pump problem at all, simply an over-eager mechanic trying to do too good a job.

## The case of the petulant packing.

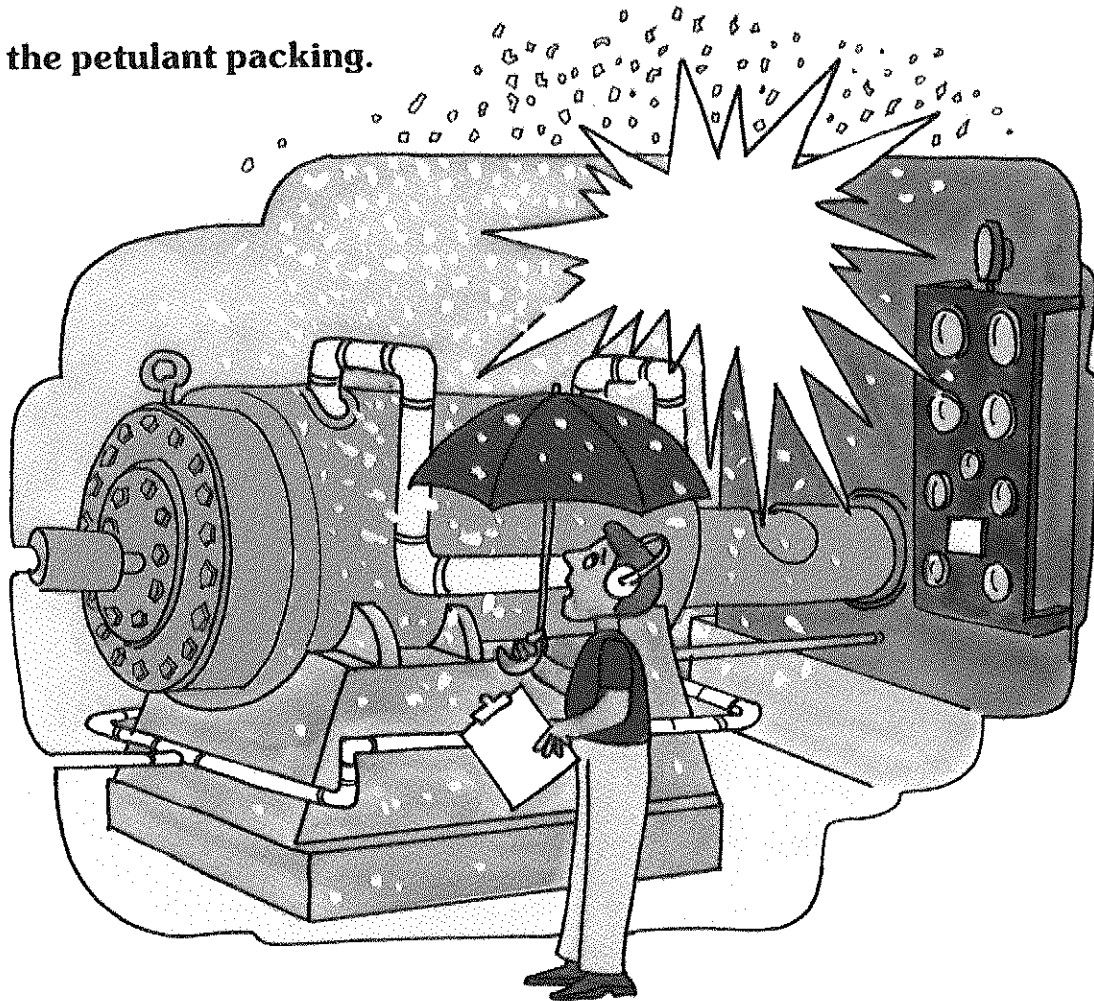

It was about a year ago that a multistage pump on boiler-feed service was presenting a baffling—and ear-splitting—mystery. The pump would start up just fine and run nicely. Then, as soon as it had run for about 12 hours, the packing would literally blow out of the stuffing box with the sound of a shotgun blast. Bits of packing would sail over operators' heads and litter the room.

This was certainly a new one. And, as the operators were quick to point out, repacking a pump twice daily is no way to run a power plant.

What happened? The shaft sleeve was about 3/8" thick chrome steel. The temperature of the water being pumped was 300° F. After a considerable number of tests in the field, we concluded that

the water being pumped was leaking down under the balancing disc, actually forcing the O-ring into an adjacent groove, which happened to be the keyhole slot for the shaft sleeve. Hot, pressurized water then worked its way down under the sleeve, heating it enough so that it expanded the few thousandths of an inch that let it rub against the packing gland, overheating and pressurizing the stuffing box. Periodically, twice a day to be exact, the packing blew out like a cork out of a popgun.

Once we figured out the cause, the solution was simple enough. A few minor modifications did the trick. Basically, a flat dummy ring was put between the O-ring in place, and the "exploding" packing was defused forever.



### The case of the illusory impeller.

In a power plant in the Midwest, four service water pumps were running in parallel. After the plant was in service for several years, operators noticed the water pressure was dropping. Before long, the situation was close to critical. On investigating the inside of the pumps, we found that one of them did not have an impeller!

“What’s the matter—did the factory forget to put an impeller in that pump?”, was the immediate question.

The pump had an impeller to start with, all right. What happened? Four pumps were too many for the amount of water to be pumped. While three pumps were making out fairly well, the fourth was recirculating and cavitating—to the point where the impeller was worn away, and there was now nothing left but the hub!

The solution was a change in operating

procedure. Now three pumps are operated close to design point, while the fourth (equipped with a new impeller) serves as standby. Plant operators have also implemented an inspection procedure, checking all pumps periodically for excessive wear. Now any change will become apparent long before the situation reaches crisis proportions—and before another impeller “disappears.”

### Hotline: 800-631-2070.

Six cases. Six happy endings. The problems were pinpointed, the fix made, and the systems are humming once again. These are the cases field service detectives like to think about back in the office, as they catch up on their paperwork and wait for that “hot-line” phone to ring again, sending them scrambling for suitcases, airline tickets, and innumerable pots for black coffee until the next case is solved.



# pump refresher

## Bernoulli's Equation

$$\frac{P_1}{\gamma} + Z_1 + \frac{V_1^2}{2g} + E_p = \frac{P_2}{\gamma} + Z_2 + \frac{V_2^2}{2g} + H_f$$

## Continuity Equation

$$Q = V_1 A_1 = V_2 A_2$$



# Basic hydraulics: How fluid flow analysis solves pumping problems.

Part 3

By John H. Doolin

A rapidly flowing stream may mean little more to the casual observer than a place to pause for relaxation; but to someone wishing to harness the power of water or put it to work, it presents a problem in fluid flow. What quantity of water is flowing? At what rate? A fireman, for example, could not extinguish a fire unless someone had first determined the pressure necessary to provide sufficient velocity from the hose nozzle, and selected the proper hose size to feed the nozzle. And a pumping system of any kind would be useless if the friction loss through the pipe were not properly determined for the flow that was ultimately required. In addition, the proper size pump has to be selected and matched to system requirements.

These and similar problems can be analyzed using just two basic equations of fluid flow (opposite). The first is *Bernoulli's Equation*, which is based on the principle of conservation of energy. The second is the *Continuity Equation*, which is based on the principle of conservation of mass.

## Bernoulli's Equation.

The principle of conservation of energy states that the total energy input to a closed conduit system (Figure 1) is equal to the total energy output from that system. In addition to the energy already in the fluid at Point 1, we have the energy added by pumps. The output is the energy in the fluid at Point 2, plus the friction loss in the system. Since this is an equation, both sides must balance exactly.

Bernoulli's Equation includes the various forms that energy can take. The left side of the equation refers to Point 1 in the system. The first energy form is pressure energy, and this is the first term in the equation,  $P_1/\gamma$ .

$P$  is the pressure of the fluid, and is expressed in units of pounds per square foot.  $\gamma$  (gamma) is the density of the fluid, and is expressed in pounds

per cubic foot. The net effect of the units in this first term is feet:

$$\frac{P}{\gamma} = \text{pressure} = \frac{\text{fluid pressure}}{\text{fluid density}} = \frac{\text{lb./ft.}^2}{\text{lb./ft.}^3} = \text{feet}$$

The second way in which fluid can receive energy is through its static elevation, which is a measure of potential energy. For most fluid-flow problems some arbitrary level, shown here as the elevation datum, is indicated as zero, and the static elevation  $Z$  is measured from there. The units of measurement are feet:

$$Z = \frac{\text{static elevation}}{\text{elevation}} = \text{feet}$$

The third term in the equation,  $V_1^2/2g$ , is an expression for kinetic energy or velocity head. The units for  $V$  or velocity are feet per second, and when these units are squared, this becomes feet squared per second squared. In the denominator, the units for gravity constant are feet per second squared. The net effect is feet:

$$\frac{V^2}{2g} = \text{kinetic} = \frac{\text{fluid velocity}^2}{2 \times \text{gravity constant}} = \frac{\text{ft.}^2/\text{sec.}^2}{\text{ft./sec.}^2} = \text{feet}$$

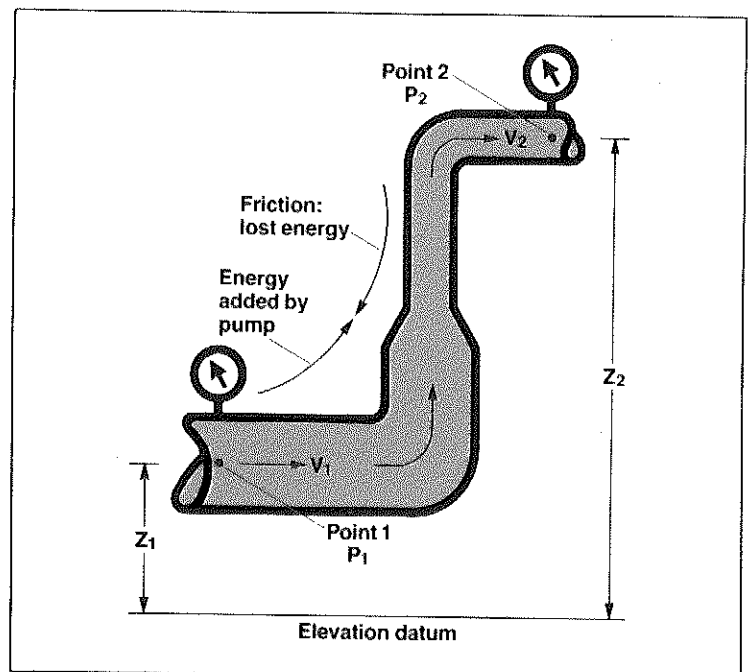

Figure 1—Conservation of energy.

In addition to the energy of the fluid at Point 1, additional energy is often added to the system between Point 1 and Point 2 by a pump. The fourth term in the equation,  $E_p$ , is the abbreviation for pump energy. This is the amount of energy that is added to the fluid between Point 1 and Point 2. Since this is an expression of energy, the units of energy are foot-pounds per pound, which again nets out to feet:

$$E_p = \frac{\text{pump energy}}{\text{energy}} = \frac{\text{ft.-lb.}}{\text{lb.}} = \text{feet}$$

The first three terms on the right side of the equation are the same as the first three terms on the left side, except they refer to Point 2. In addition, there is a final expression,  $H_f$ , which is the friction loss between Point 1 and Point 2. Friction loss is a loss of energy and is expressed in the units foot-pounds per pound, which again nets out to feet:

$$H_f = \frac{\text{friction loss}}{\text{loss}} = \frac{\text{ft.-lb.}}{\text{lb.}} = \text{feet}$$

### The Continuity Equation.

The second basic equation is the Continuity Equation, which is based on the principle of conservation of mass. That is, the total mass of fluid flowing into any closed conduit system is equal to the total mass of fluid flowing out of the same system. Whatever mass of fluid flows past one point in the system also flows past any other point in the system, which means the capacity flowing through one point in the system is equal to the capacity flowing through the second point in the system. Since capacity is equal to the product of the velocity flowing through the pipe and the cross section or area of the pipe, capacity  $Q$  is expressed as  $V_1A_1 = V_2A_2$ . The units in this equation for velocity are feet per second, the units for area are square feet. The total flow, therefore, is in cubic feet per second.

### Venturi meter flow.

To illustrate the application of these equations, we

can look at some typical problems. For example, how do we determine the flowrate of a fluid through a simple venturi meter (Figure 2)? In this problem, let's consider that the fluid flowing is gasoline with a specific gravity of .82. The flow is vertically upwards through a 12-inch diameter pipe which reduces to 6 inches in diameter.

Pressure measurements are taken in both the 12-inch and the 6-inch pipe sections. In the 12-inch diameter pipe, the pressure is measured as 20 psi. In the 6-inch diameter pipe, the pressure is 10 psi. The vertical elevation difference between the two points of pressure measurement is 4 feet. From this information, it should be possible to determine the flowrate of gasoline through this pipeline.

First, we can use Bernoulli's Equation:

$$\frac{P_1}{\gamma} + Z_1 + \frac{V_1^2}{2g} + E_p = \frac{P_2}{\gamma} + Z_2 + \frac{V_2^2}{2g} + H_f$$

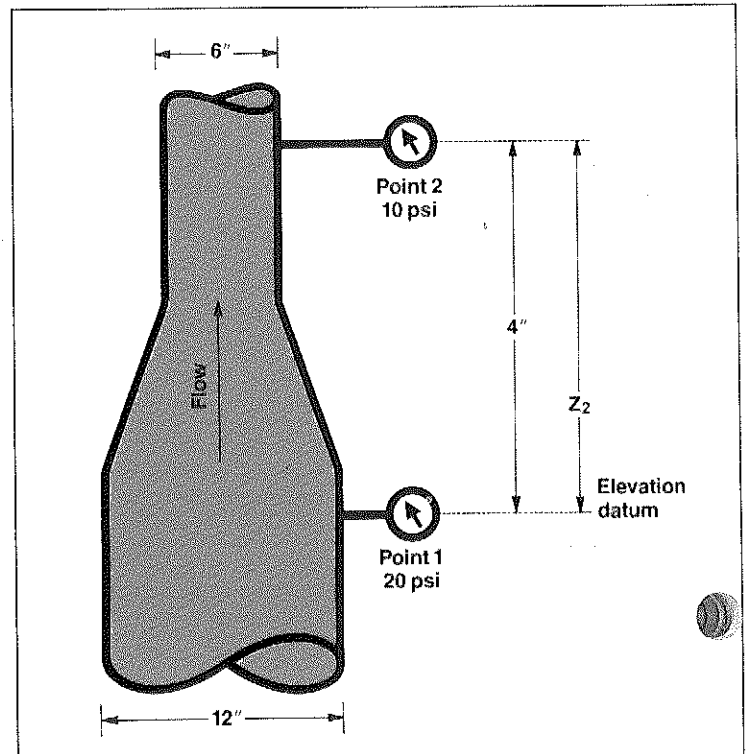

Figure 2—Venturi meter.

To simplify the problem, we can assume there is no friction loss, so  $H_f = 0$ . Since there is no pump involved, pump energy  $E_p = 0$ . This gives the equation:

$$\frac{P_1}{\gamma} + Z_1 + \frac{V_1^2}{2g} = \frac{P_2}{\gamma} + Z_2 + \frac{V_2^2}{2g}$$

Point 1 is the point of pressure measurement in the 12-inch pipe and Point 2 is the point of measurement in the 6-inch pipe. The solution continues by simple algebra, solving for the value  $V_2$  and ultimately for the total flowrate  $Q$ .

The terms are rearranged so that the pressure terms and static head terms are on the left side of the equation, and the velocity terms are on the right side:

$$\frac{P_1}{\gamma} + Z_1 - \frac{P_2}{\gamma} - Z_2 = \frac{V_2^2}{2g} - \frac{V_1^2}{2g}$$

The term  $V_1$  is replaced by its equivalent from the Continuity Equation:\*

$$\frac{P_1}{\gamma} + Z_1 - \frac{P_2}{\gamma} - Z_2 = \frac{V_2^2}{2g} - \frac{V_2^2}{2g} \left( \frac{A_2}{A_1} \right)^2$$

---

$$*Q = V_1 A_1 = V_2 A_2$$

$$V_1 = V_2 \left( \frac{A_2}{A_1} \right)$$

$$V_1^2 = V_2^2 \left( \frac{A_2}{A_1} \right)^2$$

$$\frac{V_1^2}{2g} = \frac{V_2^2}{2g} \left( \frac{A_2}{A_1} \right)^2$$

We can further simplify the terms on the right side of the equation:

$$\frac{P_1}{\gamma} + Z_1 - \frac{P_2}{\gamma} - Z_2 = \left( \frac{V_2^2}{2g} \right) \left( 1 - \frac{A_2^2}{A_1^2} \right)$$

... and continue the algebraic relationships: both sides of the equation are divided by  $1 - A_2^2/A_1^2$  and both sides are multiplied by  $2g$ :

$$2g \frac{\left( \frac{P_1}{\gamma} + Z_1 - \frac{P_2}{\gamma} - Z_2 \right)}{\left( 1 - \frac{A_2^2}{A_1^2} \right)} = V_2^2$$

Taking the square root of both sides of the equation we can determine the velocity  $V_2$ .

$$\frac{\left[ 2g \left( \frac{P_1}{\gamma} + Z_1 - \frac{P_2}{\gamma} - Z_2 \right) \right]^{1/2}}{\left[ 1 - \left( \frac{A_2}{A_1} \right)^2 \right]^{1/2}} = V_2$$

However, in order to determine the total flowrate  $Q$ , we must multiply this by the cross section area  $A_2$ , and so we arrive at the final form of the equation:

$$Q = V_2 A_2 = \frac{A_2 \left[ 2g \left( \frac{P_1}{\gamma} + Z_1 - \frac{P_2}{\gamma} - Z_2 \right) \right]^{1/2}}{\left[ 1 - \left( \frac{A_2}{A_1} \right)^2 \right]^{1/2}}$$

Now, all we need to do is substitute actual numbers for the algebraic terms. Since the area of a circle is  $A = \pi D^2/4$ , we find that  $A_1 = .785$  square feet and  $A_2 = .196$  square feet.

Using the pressure gage measurements we can also substitute real figures for the pressure and static head terms.  $P_1$  in pounds per square foot is equal to 20 psi x 144 (square inches per square foot). The density shown as  $\gamma$  is found by multiplying the specific gravity of the fluid, .82, by the density of



water, which is 62.4 pounds per cubic foot. The elevation  $Z_1$  we assume to be equal to 0, since that can be arbitrarily taken as the frame of reference or datum line. The third term,  $P_2/\gamma$ , is equal to  $10 \times 144$  divided by  $.82 \times 62.4$ . The fourth term,  $Z_2$ , is the static elevation between the two pressure gages which is equal to 4 feet. The pressure and static head terms work out to 24.2 feet. Gravity  $g$  at sea level is 32.2 feet. Substituting these numbers into the final form of the equation, we at last arrive at an answer: 8.03 cubic feet per second of gasoline are flowing through the venturi.

#### A typical pumping problem.

As another example of the use of Bernoulli's Equation and the Continuity Equation, let's look at a problem involving a pump. In Figure 3, the pump must produce 100 gallons per minute and overcome the friction in the piping (including entrance losses, etc.) of 15 feet at that capacity. The problem is to determine the total head required by the pump.

The pump takes suction from a closed tank which is under a vacuum of 28 inches of mercury. The height of water in the tank is 3 feet above the floor, which is used as the arbitrary reference point for static head measurements. The fluid flows to the pump through a 3-inch pipe, leaves the pump through a 2-inch pipe, and is discharged at an elevation 10 feet above the floor.

Let us now try to solve this problem by applying Bernoulli's Equation. The first step is to rearrange the equation to put all terms except pump energy  $E_p$  on the right-hand side:

$$E_p = \frac{P_2 - P_1}{\gamma} + Z_2 - Z_1 + \frac{V_2^2 - V_1^2}{2g} + H_f$$

Substituting into this equation,  $P_2/\gamma$  is equal to atmospheric pressure, or zero.  $P_1/\gamma$  can be converted from the 28 inches of mercury vacuum by multiplying by the ratio of 34/30: that is, a column of 34 feet of water, which is equal to one atmosphere, is also equivalent to a column of 30 inches of mercury, giving us the ratio 34/30. The static elevation  $Z_2$  was given as 10 feet;  $Z_1$  as 3 feet.

The velocity head must be determined by first finding the velocity of the fluid in the 2-inch pipe. This could be worked out using the Continuity Equation, but it's more easily found by referring to the friction flow tables published in the Hydraulic Institute Standards, where velocity, friction loss, etc. have been worked out in advance for common pipe materials. From these tables, we see that the velocity of 100 gpm in a 2-inch steel pipe is 9.5 feet per second. This value is substituted for  $V_2$  and 32.2 is substituted for  $g$ . The term  $V_1^2/2g$  is equal to 0, since the fluid in the suction chamber is moving with such a low velocity that it can be ignored.

Finally, the friction loss in the system between the suction chamber and the discharge was given in the problem as being equal to 15 feet. Adding these numbers algebraically results in an answer of 55 feet. That is, a pump must be selected so that the pump head, or total head developed, will be equal to 55 feet.

#### Determining friction loss.

In the problem just completed, we were given the information that the friction loss in the pipe system was 15 feet. However, the determination of friction loss in a pipe system is very often the most significant part of the problem. In the next issue we will see how this is done.

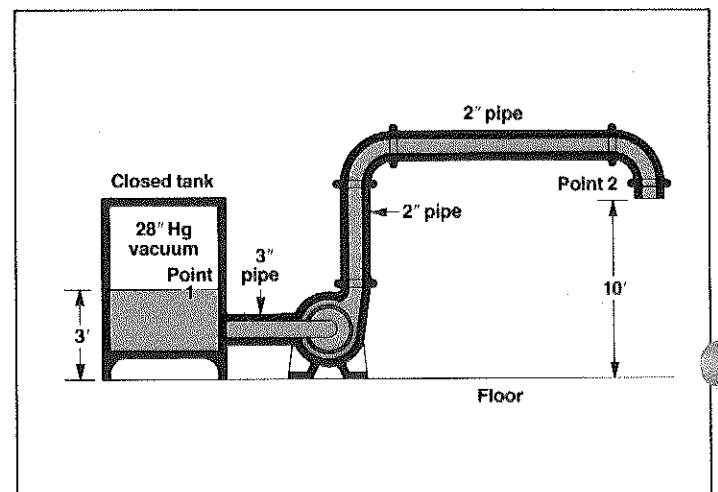

Figure 3—Pumping problem.

# WORTHINGTON PUMP



## SUBSIDIARIES AND AFFILIATES

**Worthington Pump Corporation (U.S.A.)**  
270 Sheffield St., Mountainside, N.J. 07092

**Worthington (Canada) Ltd.**  
4180 Dundas St., W. Toronto, Ontario, Canada

**Worthington Gesellschaft m.b.H (Austria)**  
Industriestrasse B. Brunn am Gebirge, Austria

**Constructions Hydrauliques  
Worthington**  
25, rue Jean Giraudoux, 75116 Paris 16 ème

**Deutsche Worthington G.m.b.H**  
Hallesdorfer Strasse 61, 2 Hamburg 71, Germany

**Worthington Argentina S.A.I.C.**  
Tucumán 829, Buenos Aires (1040), Argentina

**Worthington Colombiana S.A.**  
Avenida de las Americas No. 41-08, Bogota, Colombia

**Worthington Asia Pte. Ltd.**  
Bideford Rd., Singapore 9

**Worthington-Simpson, Ltd.**  
Newark-on-Trent, Notts., England

**Worthington S.A.**  
Bolivar, 9, Madrid 5, Spain

**Worthington Baignolles S.A.**  
20, Rue De Koufra, 44300

**Worthington de Mexico S.A.**  
Poniente 140 No. 859 Esq. Ceilan, Frac. Industrial Vallejo,  
Mexico 16, D.F. Mexico

**Worthington S.p.A. (Italy)**  
via Pirelli, 19-20124 Milan, Italy

**Worthington Sud S.p.A.**  
S.S. Sannitica Km 19 81025 — Marcianise (Caserta)

**Niigata Worthington Company Ltd.**  
No. 20 Akefune-cho, Shiba-Nishikubo Minato-ku,  
Tokyo 105, Japan

**Worthington S.A. (Maquinas)**  
Rua Araujo Porto Alegre, 36, Rio de Janeiro, Brazil

**Metcast Foundry Division**  
Worthington Ave., Harrison, N.J. 07029

**WORLDWIDE OPERATING HEADQUARTERS**  
270 Sheffield St., Mountainside, N.J. 07092

**EXECUTIVE OFFICES**  
530 Fifth Avenue, New York, N.Y. 10036

Via Pirelli, 19-20124 Milan, Italy